



Plastic-Encapsulate Diodes

SCHOTTKY BARRIER DIODE

FEATURES

- Low Forward Voltage
- Fast Switching

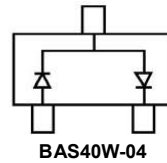
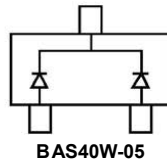
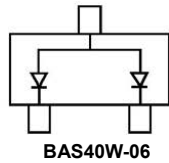
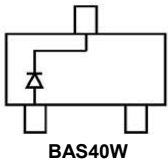
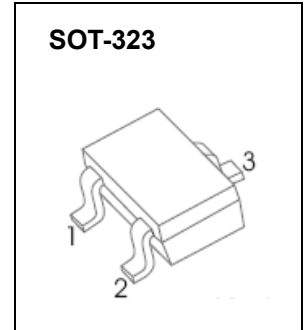

MARKING:

BAS40W	BAS40W-06	BAS40W-05	BAS40W-04

Maximum Ratings @Ta=25°C

Parameter	Symbol	Limit	Unit
Peak repetitive peak reverse voltage	V_{RRM}	40	V
Working peak reverse voltage	V_{RWM}		
DC blocking voltage	V_R		
Forward continuous current	I_{FM}	200	mA
Power dissipation	P_D	150	mW
Thermal resistance junction to ambient	$R_{\theta JA}$	667	°C/W
Junction temperature	T_J	125	°C
Storage temperature range	T_{STG}	-55~+150	°C

ELECTRICAL CHARACTERISTICS (Ta=25°C unless otherwise specified)

Parameter	Symbol	Test conditions	Min	Max	Unit
Reverse breakdown voltage	$V_{(BR)}$	$I_R=10\mu A$	40		V
Reverse voltage leakage current	I_R	$V_R=30V$		200	nA
Forward voltage	V_F	$I_F=1mA$ $I_F=40mA$		380 1000	mV
Diode capacitance	C_D	$V_R=0, f=1MHz$		5	pF
Reverse recovery time	t_{rr}	$I_{rr}=1mA, I_R=I_F=10mA$ $R_L=100\Omega$		5	ns

